

Installation Instructions for John Deere™ Slide Tube Assembly (for Ladder Mount SmartBox®)

The Slide Tube Assemblies are used with the Ladder Mount Brackets for the center rows only on John Deere CCS-type planters (*i.e.* 1770, 1790, DB). The Rear Row Mount Brackets cannot be used on these center rows as the planter's ladder/stairway would interfere with the SmartBox chemical transfer containers.

Begin the installation process with the planter being placed and secured in the raised position. Attach the SmartBox Ladder Mount Brackets, base row units (*with meters attached*), and in-furrow drop tubes.

Next, cut two (2) $\frac{3}{4}$ " long each pieces of the $\frac{1}{2}$ " inside diameter (ID) hose. Place one (1) of these hose pieces onto the SmartBox meter nipple, and the other piece onto the material inlet opening of the in-furrow drop tube.

Then cut an approximate 7" long piece of the $\frac{3}{4}$ " ID hose. Slide one end of this hose over the $\frac{1}{2}$ " ID hose that has been placed onto the meter nipple and secure with a hose clamp. Slide the other end of this 7" long hose over the SLIDE TUBE, BONDED LONG and secure with a hose clamp.

Attach the remaining $\frac{3}{4}$ " ID hose to one end of the TUBE MID; PVC LONG and secure with a hose clamp. (*This hose will be cut to length and clamped later.*)

Place a mark on the opposite end of the TUBE MID; PVC LONG approximately $\frac{3}{4}$ " from the end. Place this marked end up into the SLIDE TUBE, BONDED LONG.

Hook one end of the spring to the hose clamp found on the top of the TUBE MID; PVC LONG and the other end of the spring to the hose clamp found on the bottom of the SLIDE TUBE, BONDED LONG.

Now extend the TUBE MID; PVC LONG so that only the $\frac{3}{4}$ " marked end is sticking into the SLIDE TUBE, BONDED LONG. (*This represents the maximum extension of the Slide Tube Assembly.*)

While holding the slide tubes in this manner, mark and cut the length of $\frac{3}{4}$ " ID hose and attach to the in-furrow drop tube with a clamp.

Please refer to the attached Drawing No. SB012433: **KIT; SB SLDE TUBE.**

**Always use and follow planter manufacturers owner's manual recommended safety guidelines*



REVISIONS

REV	DATE	DESCRIPTION	BY	ECO
B	8/20/13	ADDED DRAWING	ATM	7627

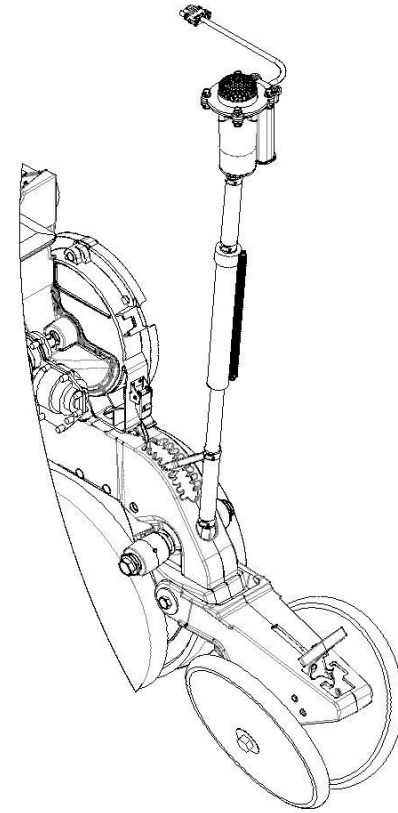
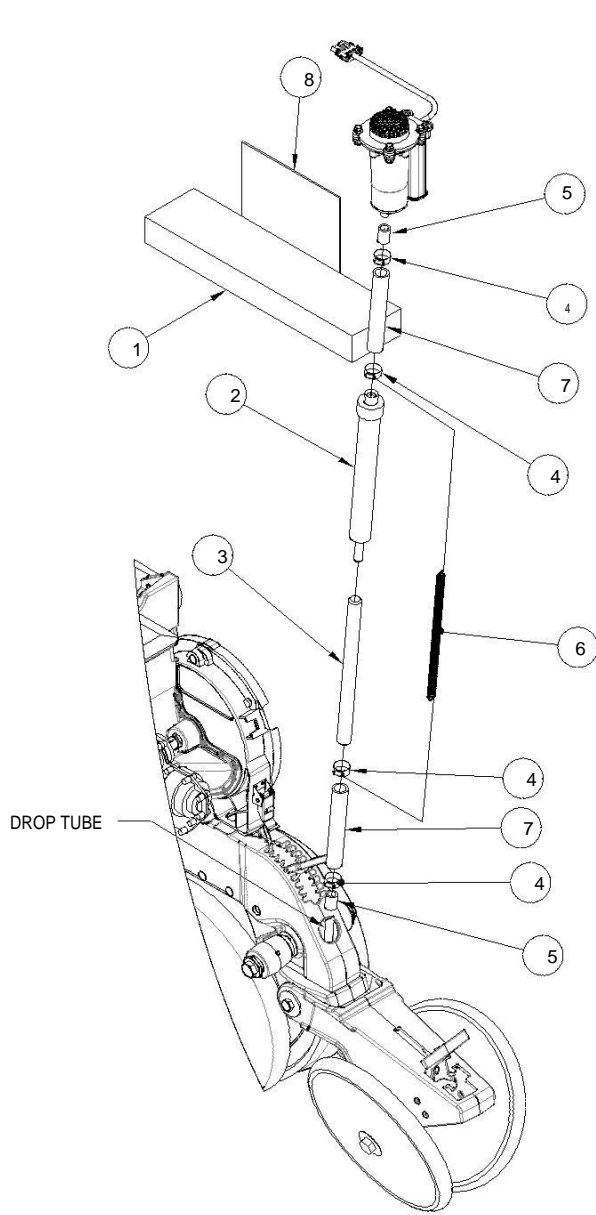

8	1	WF-2013-04	LIT; SMARTBOX SLIDE TUBE ASSY
7	5 FT	SIGHT-34	HOSE; 3/4" ID X 1/8" SIGHT HOSE
6	1	SB207	SPRING; EXT. 7/16" X 10 1/4" X .041"
5	.5 FT	K3150-050	HOSE; 1/2" ID, VINYL REINF. CLR
4	4	#12J	CLAMP; 3/4" - 1.25" HOSE
3	1	010052	TUBE MID; PVC LONG
2	1	010048	SLIDE TUBE; BONDED LONG
1	1	9030-0029	BOX; 18" X 4" X 2"
ITEM NO	QTY.	PART NUMBER	DESCRIPTION

MATERIAL: Material <not specified> APPROX. WEIGHT: 55.25LBS

THE INFORMATION CONTAINED IN THIS DRAWING IS THE PROPERTY OF AMVAC CHEMICAL CORP. THIS DRAWING MAY NOT BE USED FOR MANUFACTURING WITHOUT THE WRITTEN PERMISSION OF AMVAC CHEMICAL CORP.

AMVAC CHEMICAL CORPORATION

DESCRIPTION: KIT; SB SLIDE TUBE

DWG NO: SB012433

REV B

DATE: 8/20/13

SCALE: N/A

SHEET 1 OF 1