

REVISIONS

REV	DATE	DESCRIPTION	BY	ECO
A	6/6/13	RELEASE TO PRODUCTION	ATM	7610

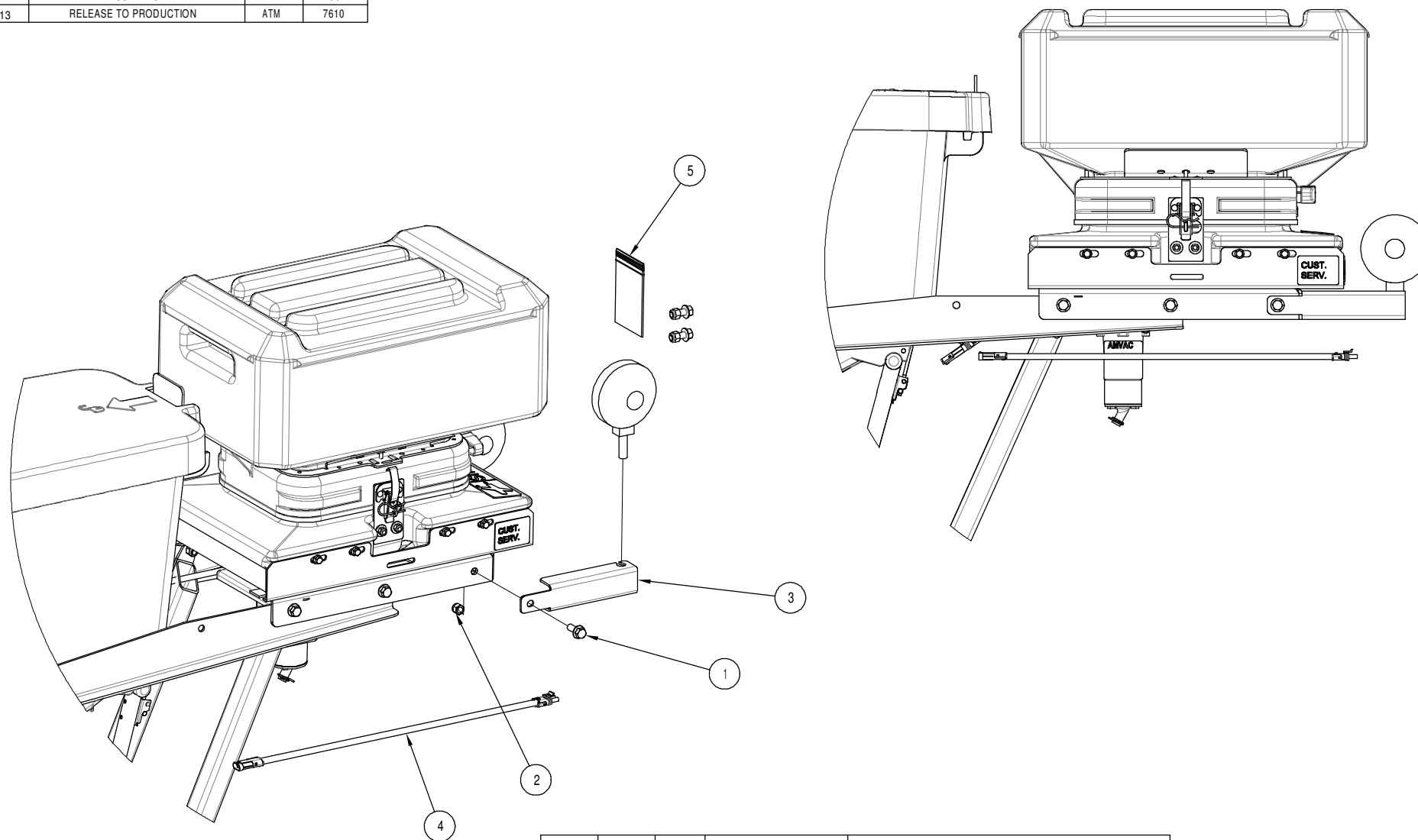

NOTES:
X = ITEMS INCLUDED IN PARTS BAG SUBASSEMBLY.

NOTE:	ITEM NO.	QTY.	PART NUMBER	DESCRIPTION
	5	1	SB021614	KIT; WHITE 9180, 9831, LIGHT BOLT
	4	2	SB021557	ASSY; WIRING, LIGHT EXTENSION
	3	2	SB021549	BRACKET; LIGHT
X	2	2	LN-038-NI	LOCKNUT, NYLON INSERT; 3/8", GR5
X	1	2	BHF-038-100-5	BOLT, FLG; 3/8"x1" GR 5

MATERIAL: Material <not specified>		APPROX. WEIGHT: 137.97LBS	
DIMENSIONS ARE IN INCHES		THE INFORMATION CONTAINED IN THIS DRAWING IS THE PROPERTY OF AMVAC CHEMICAL CORP. THIS DRAWING MAY NOT BE USED FOR MANUFACTURING WITHOUT THE WRITTEN PERMISSION OF AMVAC CHEMICAL CORP.	
TOLERANCES (EXCEPT AS NOTED)			
2 PLACE DECIMALS ± .06			
3 PLACE DECIMALS ± .030			
ANGLES ± 1°		AMVAC CHEMICAL CORPORATION DESCRIPTION: ASSY; SB WHITE 9180 & 9831 LIGHT DWG NO. SB021556 DATE: 6/20/13	
DRAWN: ATM	SIZE: B	SCALE: NA	SHEET 1 OF 1